

Illusion

Ceiling hood

Specification sheet



Learn more

MEASUREMENTS

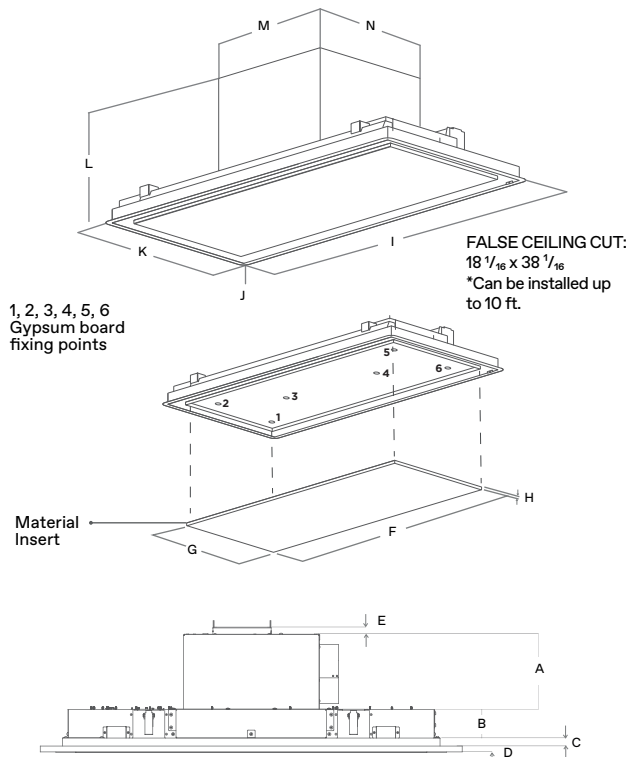

EIL640WH / EIL640DW	
A	7 9/16" (19 cm)
B	2 7/8" (7.35 cm)
C	2 9/16" (2.06 cm)
D	9/16" (1.4 cm)
E	3/4" (1.9 cm)
F	35 3/8" (90 cm)
G	14 7/8" (37.7 cm)
H	3/8" (0.9 cm)
I	40" (101.6 cm)
J	R20" (R50 cm)
K	19 1/16" (50 cm)
L	11 1/4" (30.2 cm)
M	13" (33 cm)
N	15 3/8" (39 cm)

DESCRIPTION

First panel-ready ceiling hood in the market, perfectly fitting the ceiling texture of the living space, disappearing like a true Illusion. Also naturally saves valuable kitchen space and frees the area of inconvenient obstructions cleverly hiding a powerful extraction system that guarantees always clean air in the living space. Combining discreet shapes and high performance, Illusion has been created for consumers who ask for an essential and bespoke style without compromising on functionality.



FEATURES

- Special materials
- Total integration
- Perimeter aspiration
- Super easy installation
- Long life filter
- Tune white
- Dim light
- Remote control



GENERAL PROPERTIES

Width	40"	40"
Model	EIL640WH	EIL640DW
Dimensions	40"W x 19 1/16"D x 11 1/4" H	
Blower Type ¹ (Internal)	600 CFM (3-speed+ boost)	
Noise (Min-max sones) ¹	1.8-6.8 Sones	
Electrical	120V-60Hz, 578W	
Illumination	2 Strip LED, 14W	
Finish	Metal white with white frame	Naked panel (stainless steel) + stainless steel frame
Controls (Included)	White remote control	
Grease filters	Dishwasher-safe, anodized aluminum, mesh filter + perimeter aspiration	
Duct transition	Round 6" (multi directional)	
Installation type	Ducted or recirculation (kit sold separately)	
Installation height	Can reach ceiling heights up to 10'	

KITS

Recirculating	KIT0167875 (Contains 3 long life carbon filters)
Optional remote control	KIT0121469 (Black) / KIT0121468 (White)

WARRANTY:² Two (2) Years Parts & In-Home Labor. Earn an additional One (1) Year of Parts & In-Home Labor by registering on elica.com



The product images shown are for illustration purposes only and may not be an exact representation of the product.
¹ CFM and Noise data indicate the performance of the hood blower tested according to international standards. For AHAM Certified Ratings, established in accordance with California Title 24 Standardized test procedure, please refer to AHAM Certified Product Directory. Electric Ratings are declared according to UL.

² For valid warranty extension, register within 3 months from purchase. For USA & Canada Users Only.