

Give a splash of Italian design to your professional kitchen with Vavano's crisp lines, seamless welded corner craftsmanship, beveled rim and gleaming stainless steel. No ear plugs required with Vavano's HUSH sound suppression system, which enables you to comfortably talk and entertain, even when cooking up a storm. Available in 36" and 48" widths, Vavano features backlit hidden knob controls, which operate the 4-speed blower and LED lighting. Easy maintenance and cleaner kitchen are assured with professional stainless steel angled baffle filters.

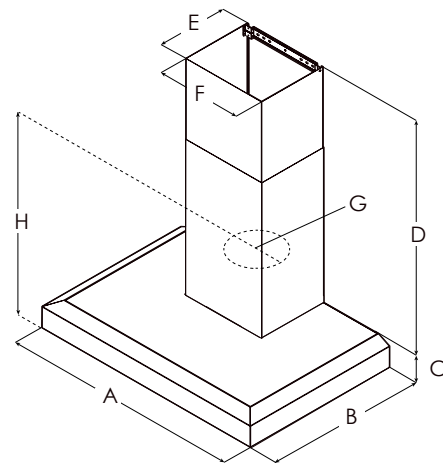

	EVV636S1	EVV648S1
A	36" (91.4 cm)	48" (122 cm)
B	24" (61 cm)	
C	5" (12.8 cm)	
D	Max: 54" (137 cm) Min: 30" (76.3 cm)	
E	10 <sup>5</sup> / <sub>8</sub> " (26.9 cm)	
F	13 <sup>5</sup> / <sub>16</sub> " (33.2 cm)	
G	8" (20.3 cm)	
H	20 <sup>1</sup> / <sub>16</sub> " (52.6 cm)	

SPECIFICATIONS

Width:	36" Unit	48" Unit
Model:	EVV636S1	EVV648S1
Dimensions:	36"W x 24"D x Min 30" Max 51" H	48"W x 24"D x Min 30" Max 51" H
Blower Type(internal):**	600 CFM (4 -speed)	
Noise (sones):**	7 Sones	
Finish:	Stainless Steel	
Controls:	Fully Retractable Rotating Knobs with Blue Backlighting	
Illumination:	2 LED Lights, 6.5 W, 3000 K, 540 Lumen/Lamp	
Grease Filter:	Dishwasher-Safe, Professional Stainless Steel Baffle 2 for 36" & 3 for 48"	
Duct Transition:	8" Round with Back Draft Damper (top only)	
Installation Type:	Ducted Installation Only	
Telescopic Chimney:	Can reach ceiling heights 7'6" - 10'6" (over electric cooking), 8'0" - 10'6" (over gas cooking)	
Electrical:	120V - 60 Hz, 490 W	
KITS:		
Long Chimney Extension Kit 12":	KIT0146881 (Can reach up to 13'6")	KIT02785 (Can reach up to 13'6")
1200 CFM Inline Blower Kit:	KIT0154387	
1200 CFM External Blower Kit:	KIT0153054	
Electronic CFM Reduction Bypass Kit:	KIT0185752	
WARRANTY:***	Two (2) Years Parts & In-Home Labor. Earn an additional One (1) Year of Parts & In-Home Labor by registering on elica.com.	

PLUS FEATURES

- HUSH SYSTEM** - An exclusive sound deadening technology that effectively reduces sound levels by over 35%
- LED CONSUMER REPLACEABLE BULB** - High quality LED lighting usually requires a skilled technician to replace lamps. Avoid this expense with Elica's new LED lamps that enable homeowners to replace in seconds
- SEAMLESS CRAFTSMANSHIP** - Heavy gauge stainless steel "Seamless" construction that delivers refined elegance.
- STAINLESS STEEL BAFFLE FILTERS WITH GREASE COLLECTORS** - Designed for high airflow cooking, the "S" shape design traps high volumes of grease
- PROFESSIONAL PERFORMANCE** - Special features and high performances for models with aspiration capacity between 600 and 1200 CFM's
- HEAT GUARD** - Senses extreme temperatures (>158°F) and automatically adjusts the blower speed to HIGH



The product images shown are for illustration purposes only and may not be an exact representation of the product.  
<sup>1</sup> CFM and Noise data indicate the performance of the hood blower tested according to international standards. For AHAM Certified Ratings, established in accordance with California Title 24 Standardized test procedure, please refer to AHAM Certified Product Directory. Electric Ratings are declared according to UL.  
<sup>2</sup> For valid warranty extension, register within 3 months from purchase. For USA & Canada Users Only